



**ELECTRO-HYDRAULIC POWER UNIT  
GEN4 | HRP-BAT-4**



**HRP-BAT GEN 4**

**ELECTRO-HYDRAULIC BREACHING KIT**

The GEN4 Hydraulic Power Unit delivers 10,000psi of hydraulic pressure, powered by DeWalt 60V FLEXVOLT batteries for up to 300 breaches per charge. MIL-STD 810G tested and field-proven by the USMC, USAF and NYPD ESU, the GEN4 power unit offers unmatched reliability, performance, and safety for any mission.

Quick-connect hydraulic fittings for seamless tool swaps

Two-button control interface, provides an easy return point for quick manipulation



MOLLE Tool holders offer convenient tool storage



Laser cut MOLLE

The custom FirstSpear backpack design allows high, tight wear for enhanced mobility without interfering with other tactical gear

Noise-canceling enclosure reduces sound output to just 57dB at full pressure

<b>WEIGHT W BATTERY</b>	9.75 KG   21.5 LBS
<b>DIMENSIONS</b>	6.75" x 10" x 13.5" 17.1CM x 25.4CM x 34.3CM
<b>REMOTE BATTERY</b>	HOSE MOUNTED 60V LI-ION
<b>WORKING PRESSURE</b>	690 BAR   10,000 PSI

\* Pictured with optional HDP11 Tool Head



### □ LONG STROKE HYDRAULIC DOOR PUSHER | HDP11

The HDP11 Long Stroke Door Pusher is a powerful hydraulic breaching tool designed for tactical operations. Compact, lightweight, and built for speed, the HDP11 offers reliable performance in high-stakes breaching scenarios.



#### Features:

- Ultra-Thin Gapping Blades (0.1 inches / 2.5 mm)
- Stair-Step Blade Design
- 11-Inch Stroke
- Gas Spring Retraction Mechanism
- Swivel Hydraulic Hose Connector
- Ergonomic Foam-Covered Grab Handle

#### HDP11

<b>WEIGHT</b>	12.34LBS   5.6 KG
<b>DIMENSIONS</b>	5 x 4 x 18 IN 127.0 x 101.6 x 457.2 MM
<b>STROKE</b>	11 IN   279.4 MM
<b>PUSHING POWER</b>	10,000 LBS   4535KG
<b>WORKING PRESSURE</b>	690 BAR   10,000 PSI



### 4" DOOR PUSHER | HDP4

### JAMB SPREADER BAR | JS41

The HDP4+JS41 Hydraulic Door Pusher and Jamb Spreader is a versatile 2-in-1 breaching tool designed for heavier breaching applications. Built from heat treated steel and featuring quick-connect hydraulic fittings, the HDP4+JS41 is compact, durable, and ideal for both inward and outward swing doors.

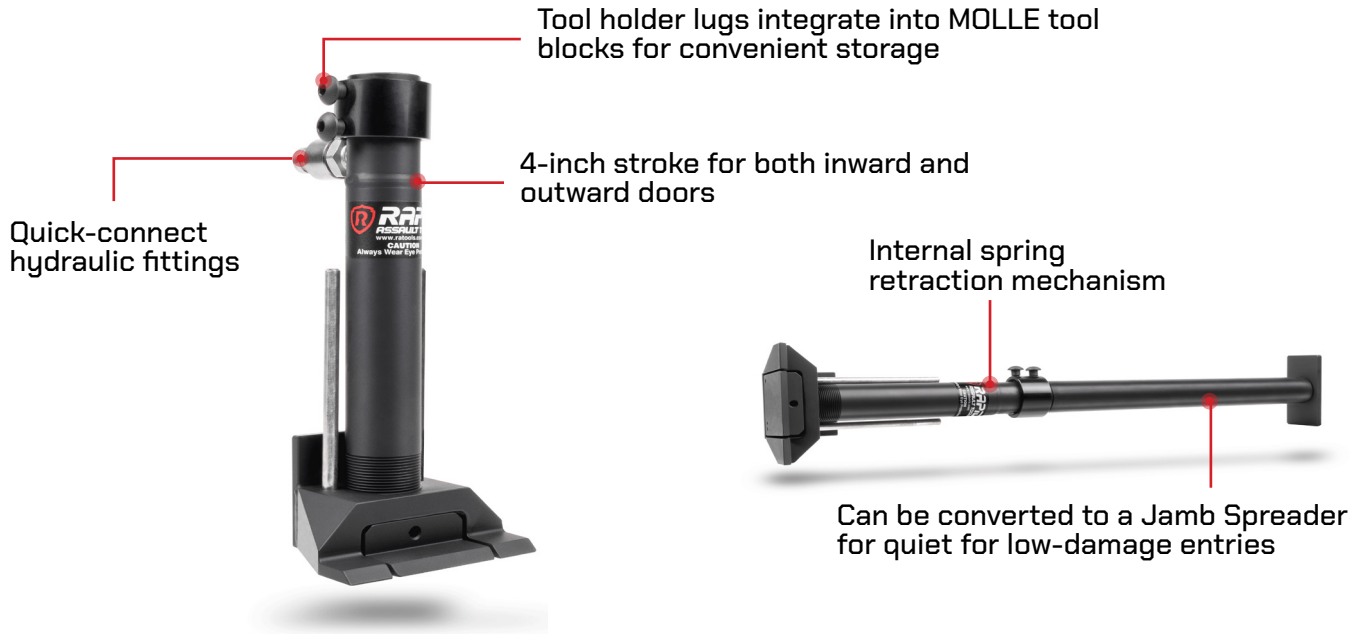

#### Features:

- 2-in-1 Tool: Door Pusher and Jamb Spreader
- Door Pusher (HDP4): Delivers 4 inches of stroke for inward and outward swing doors
- Jamb Spreader (JS41): Ideal for wellness checks or covert missions requiring minimal noise and little structural damage.
- Internal Spring Retraction Mechanism
- Quick-Connect Hydraulic Fittings
- MOLLE-Compatible Storage and Hands-Free Operation

#### HDP4 (Part #1 of 2-in-1 Ratspreader)

<b>WEIGHT</b>	7 LBS   3.2 KG
<b>DIMENSIONS</b>	10.4 x 4.9 x 3.7 IN 264 x 114 x 98 MM
<b>STROKE</b>	4 IN   102 MM
<b>PUSHING POWER</b>	10,000 LBS   4535KG
<b>WORKING PRESSURE</b>	690 BAR   10,000 PSI

#### JS41 (Part #2 of 2-in-1 Ratspreader)

<b>WEIGHT</b>	5.7 LBS   2.6 KG
<b>LENGTH MIN</b>	660 MM   26 IN
<b>LENGTH MAX</b>	1041 MM   41 IN
<b>PUSHING POWER</b>	10,000 LBS   4545 KG
<b>WORKING PRESSURE</b>	690 BAR   10,000 PSI

□ **3 TON SPREADER | HS4** (INCLUDED IN HRP4)

The HS4 Three Ton Hydraulic Spreader is a compact yet powerful breaching tool designed for tasks such as light vehicle extrication, sliding door removal, and window grill dismantling. Built from durable steel and compatible with GEN4, GEN3, and manual pump power units, the HS4 is highly maneuverable and perfect for medium-gap breaches in both tactical and rescue operations.

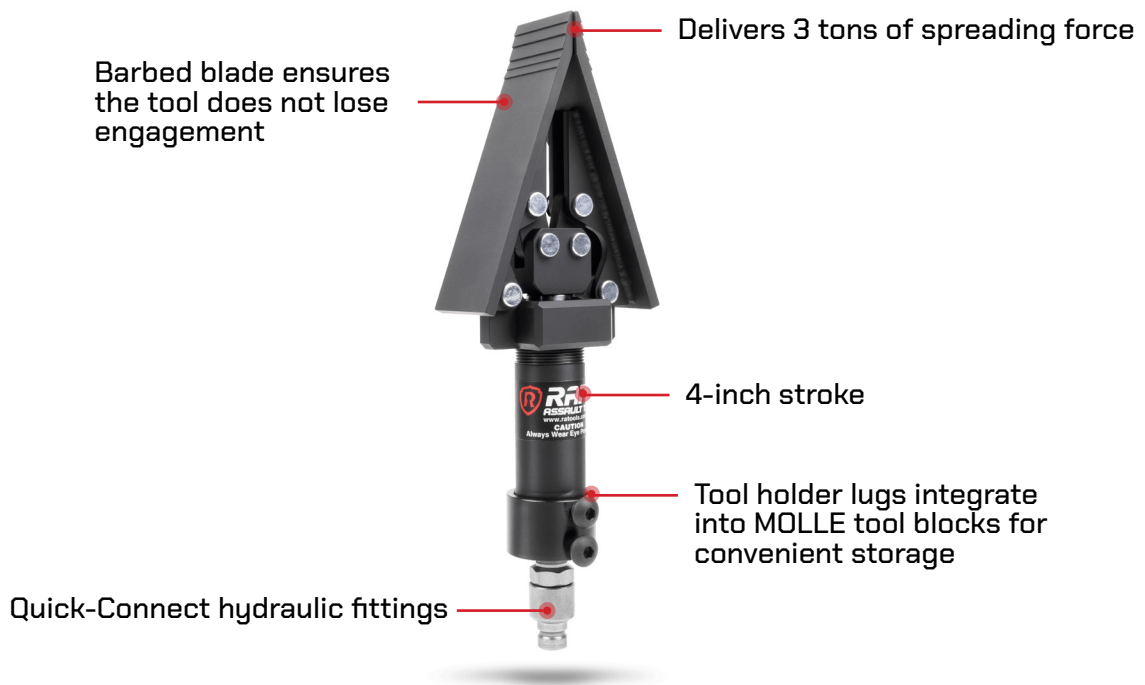

**Features:**

- Powerful 3-Ton Spreading Force
- 4-Inch Stroke
- Compact and Lightweight Design
- Durable Steel Construction
- Quick-Connect Hydraulic Fittings
- Lossless Hydraulic Fittings Design

<b>WEIGHT</b>	7 LBS   3.0 KG
<b>LENGTH</b>	13.2 IN   33.6 CM
<b>ARM WIDTH</b>	2 IN   5.08 CM
<b>WORKING PRESSURE</b>	10,000 PSI   700 BAR
<b>CLOSED BLADE HEIGHT</b>	0.16 IN   4 MM
<b>EXT. BLADE HEIGHT</b>	4.33 IN   10.9 CM
<b>RATED LOAD AT BLADE TIPS</b>	3 TONS   2,720 KG

### □ HYDRAULIC BOLT CUTTER | HBC30

The HBC30 Hydraulic Bolt Cutters deliver powerful cutting performance in a compact design. Features quick-change heat-treated steel blades with a safety mechanism to prevent fractures, ensuring durability and efficiency in the field. Ideal for tactical and industrial applications, these cutters are perfect for cutting locks, fences, and rebar in high-pressure situations where reliability is key.

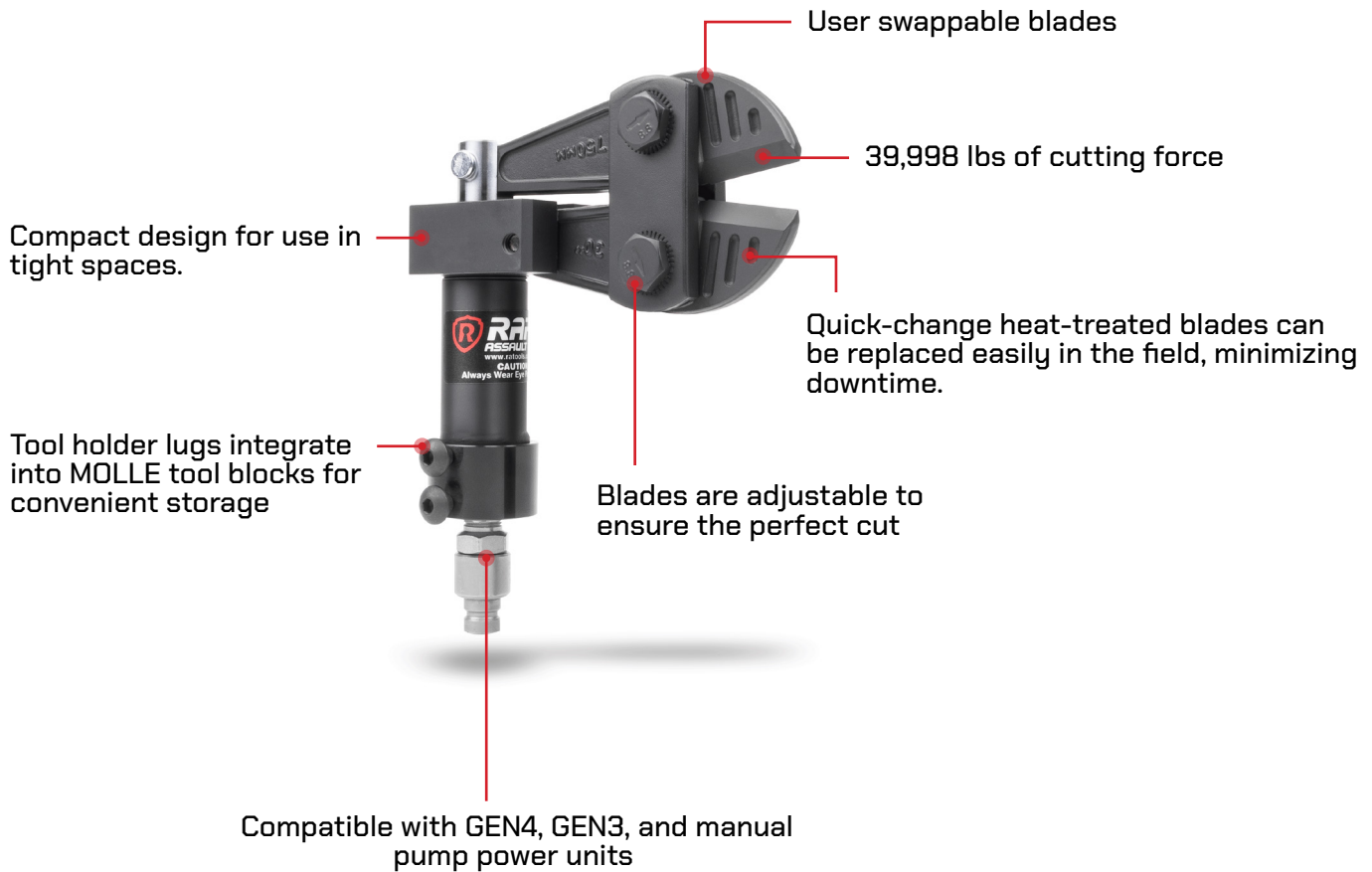

#### Features:

- Powerful Cutting Force
- Compact and Lightweight Design
- Quick-Change Heat-Treated Blades
- 10,000 PSI power unit required
- Seamless Integration

<b>WEIGHT</b>	6.8 LBS   3.1 KG
<b>DIMENSIONS</b>	8.3 X 7.2 X 2.4 IN   213 X 184 X 59 MM
<b>CUTTING CAPACITY</b>	.27 IN   7 MM with High Harness HRC40 .51 IN   13 MM with Low Harness HRC20
<b>CUTTING FORCE</b>	39,998 LBS   18143 KG
<b>WORKING PRESSURE</b>	10,000 PSI   690 BAR



**LARGE HYDRAULIC BOLT CUTTER | HBC36**

The HBC36 Hydraulic Bolt Cutters deliver powerful cutting performance in a compact design. Features quick-change heat-treated steel blades with a safety mechanism to prevent fractures, ensuring durability and efficiency in the field. Ideal for tactical and industrial applications, these cutters are perfect for cutting locks, fences, and rebar in high-pressure situations where reliability is key.

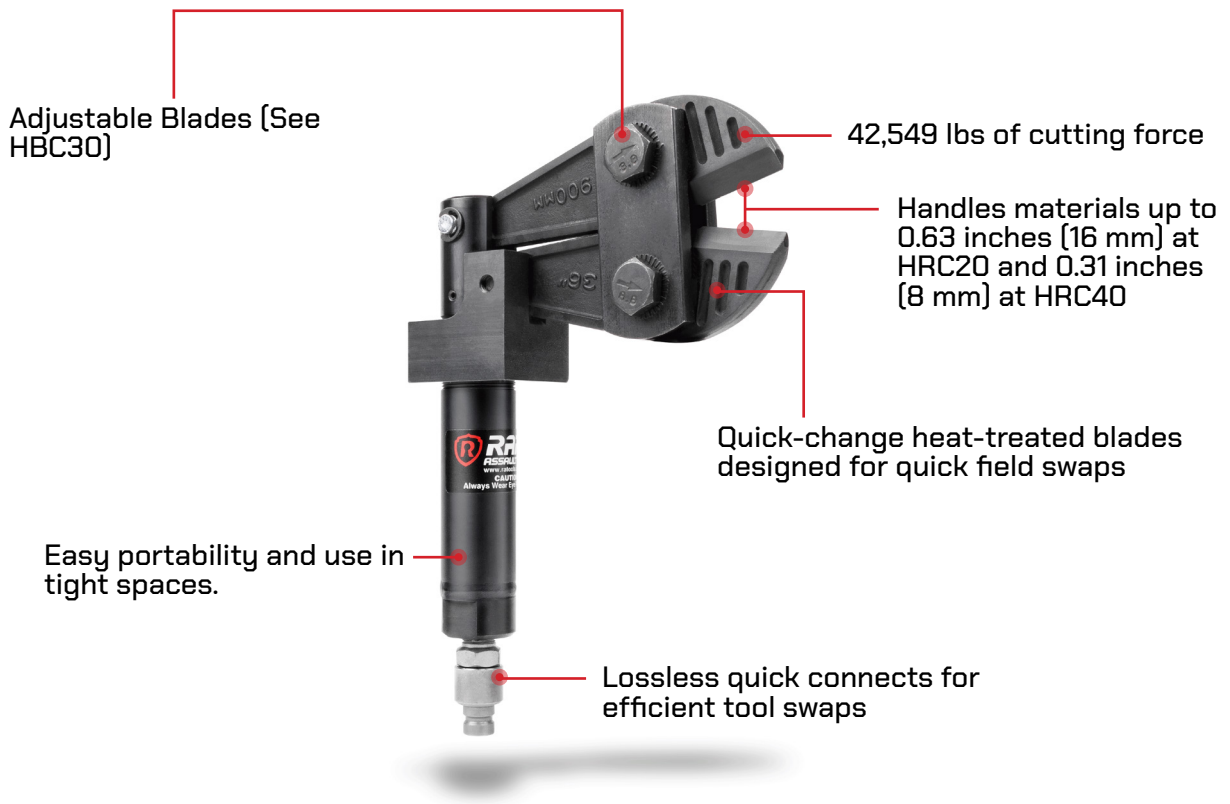

**Features:**

- Enhanced Cutting Power
- Larger Cutting Capacity
- Quick-Change Heat-Treated Blades
- Compact and Maneuverable

<b>WEIGHT</b>	9.92 LBS   4.5 KG
<b>DIMENSIONS</b>	10.6 X 7.87 X 2 IN   69 X 200 X 51 MM
<b>CUTTING CAPACITY</b>	.31 IN   8 MM with High Harness HRC40 .63 IN   16 MM with Low Harness HRC20
<b>CUTTING FORCE</b>	42,549 LBS   9,300 KG
<b>WORKING PRESSURE</b>	10,000 PSI   690 BAR

### □ HYDRAULIC REBAR CUTTER | HRC625

The HRC625 Hydraulic Rebar Cutter delivers 15,600 lbs [7.8 tons] of cutting force in a lightweight, 6.3 lbs [2.8 kg] design. With high-grade tool steel blades and a guillotine-style cutting action, it ensures precise, jam-free cuts on wire rope, rebar, and steel cable. The hinged head mechanism captures material easily, while the internal spring retraction allows for rapid consecutive cuts. Compatible with GEN3, GEN4, and manual pumps, it offers quick-connect fittings for seamless operation. The field-replaceable blade can be replaced in seconds, making it an ideal tool for tactical, rescue, and industrial use.

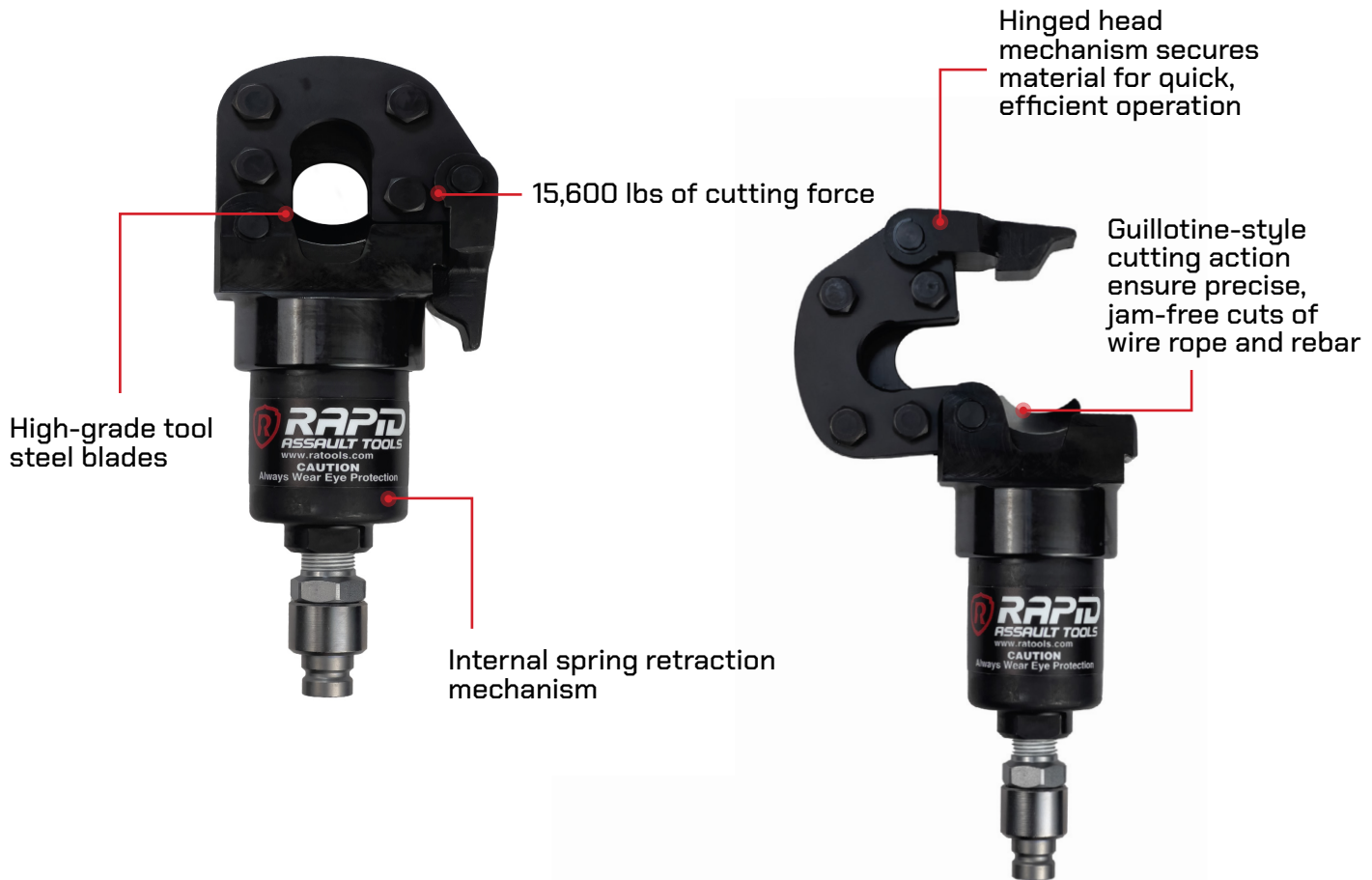

#### Features:

- Durable Tool Steel Blades
- Guillotine-Style Cutting
- 15,600 lbs Cutting Force
- Hinged Head Mechanism: Secures material for efficient cutting with no engagement issues.
- Lightweight and Portable, ideal for confined spaces and easy transport

<b>WEIGHT</b>	2.8 KG   6.3 LBS
<b>DIMENSIONS</b>	235 x 86 x 64 MM   9.25 x 3.75 x 2.5 IN
<b>CUTTING DIAMETER</b>	16 MM   .625 IN
<b>CUT POWER</b>	7.8 TON   15,600 LBS
<b>WORKING PRESSURE</b>	690 BAR   10,000 PSI

### □ TOOL LIGHT | HTL-1

The HTL-1 Tool Light integrates seamlessly with Rapid Assault Tools breaching equipment, providing hands-free illumination in low-light environments. Featuring the Princeton Tech MPLS light, available in white, red, or IR, it attaches via a custom picatinny magnetic mount, allowing for easy repositioning without interfering with tool operation. Compact and versatile, the HTL-1 ensures optimal visibility during tactical operations while maintaining tool efficiency.



#### Features:

- *Princeton Tech MPLS Light: Available in white, red, or IR for tactical lighting versatility.*
- *Custom Picatinny Magnetic Mount: Easily re-positionable for hands-free illumination.*
- *Seamless Tool Integration: Designed to integrate with breaching tools like the HDP11.*
- *Compact Design: Lightweight and unobtrusive, ensuring it doesn't interfere with tool operation.*
- *Hands-Free Operation: Provides optimal visibility in low-light tactical environments.*





## HRP-BAT GEN 4 ELECTRO-HYDRAULIC BREACHING KIT

The Rapid Assault Tools Hydraulic Breaching Tool Cases by Pelican are rugged, waterproof, and dustproof storage solutions featuring custom-cut foam to securely hold the complete GEN4 Hydraulic Breaching Kit. Built for durability and mobility, these cases protect your tools in transit and on-site, ensuring your equipment stays mission-ready in the toughest environments.



### □ HYDRAULIC TOOL CASE 1 HTC-1

**Holds:**

- Gen4 Power Unit 60V fast charger
- Qty 2 60V 6Ah Dewalt Batteries
- HDP11 - Long Stroke Door Pusher or HRC-625



### □ HYDRAULIC TOOL CASE 2 HTC-2

**Holds:**

- HDP11 - Long Stroke Door Pusher
- HDP4 + JS41 - Door pusher Jamb spreader Combo
- HS4 - 3 Ton Spreader
- HBC30 - Hydraulic Bolt Cutter
- HBC36 - Large Hydraulis Bolt Cutter
- \* HRC-625 can be stored in place of HDP11

\*Tools not included



**SCAN FOR  
MORE INFO**